

## **WARNING! READ BEFORE INSTALLATION**

### **General**

A failure resulting in injury or damage may be caused by excessive overpressure, excessive vibration or pressure pulsation, excessive instrument temperature, corrosion of the pressure containing parts, or other misuse. Consult Ashcroft Inc., Stratford, Connecticut, USA before installing.

### **Storage**

The measuring instruments should remain in original packing until installation. Storage temperatures must not exceed  $-20\text{ }^{\circ}\text{C}$  or  $+60\text{ }^{\circ}\text{C}$ , unless specified otherwise. Please consult the factory datasheets for the specific product specifications.

### **Installation of RTD Assemblies**

When installing an RTD assembly, the correct insertion length must be used. If an RTD has an insufficient insertion length, convection errors may occur. These errors occur when the heat of the process media is conducted away from the sensing element causing the RTD to measure a temperature that is lower than the temperature of the process media. To avoid convection errors and to obtain more accurate temperature measurements:

For water and other liquids:

The insertion length should be 5 to 6 times the outer diameter of the thermowell plus the length of the sensing element, typically about 2 inches or 50 mm.

For gases, steam, and air:

The insertion length should be 10 to 15 times the outer diameter of the thermowell plus the length of the sensing element, typically about 2 inches or 50 mm.

For applications that require small insertion lengths:

The insertion length should be a minimum of 1.5 times the length of the sensing element

If the insertion length of the RTD assembly is larger than the diameter of your pipe the assembly should be installed at an elbow or bend. If the assembly is installed this way, the sensor should be installed so it is against the flow (see Fig. 1)

**Figure 2** shows a typical setup that helps minimize convection errors

**Table 1** shows typical insertion lengths for different pipe diameters. These values should only serve as a general guide.

### **Installation of Thermocouple Assemblies**

When installing a thermocouple assembly, the temperature of the cold junction is equally as important as the temperature of the hot junction. This is because the mV output created by the thermocouple depends on the temperature difference between the two junctions. The installation location of a thermocouple is typically determined by the location of the cold junction, the location of the hot junction, application and process medium being sensed. Evaporation, diffusion, oxidation, corrosion, and other

forms of contamination of the sensor can cause the drift to occur. It is essential that proper protection is provided whenever adverse conditions are encountered.

Errors in temperature can occur when the thermocouple is connecting to the reference junction with wire with different thermoelectric properties from the thermocouple. This is referred to as a cold-junction error. Cold-junction errors will increase as the difference in temperature between both ends of the cable increases. To overcome cold-junction errors, thermocouples should be connected directly to the reference junction or by using a compensating cable. Compensating cables are made from alloys with similar thermoelectric characteristics as the thermocouple materials used in the sensor assembly.

To reduce sources of potential error and contamination thermocouples and the compensating cable should be cleaned before installation to assure good electrical contact.

Similar to RTDs, thermocouples can be affected by convection errors. Convection errors occur when heat is conducted away from the hot junction causing the thermocouple to indicate a temperature lower than that of the medium being measured. To minimize convection errors the rules that apply to RTD installation should be followed. A general rule, a minimum insertion length of 10 times the outside diameter of the thermowell should be used when installing a thermocouple.

Once a thermocouple has been installed it is not recommended to change the insertion length of that thermocouple. Changing the length of the thermocouple may result in thermal lag. Thermal lag will increase the error of the thermocouple because the temperature sensing portion of the thermocouple is no longer in direct contact with the bottom or sides of the thermowell.

To maximize the accuracy of a thermocouple, the thermocouple should only be used to measure a single temperature or temperatures larger than the previous temperature it measured. Heat cycling errors are similar to the errors caused by evaporative corrosion due to changes in insertion length.

### **Maintenance**

RTD and thermocouple wires, circuits, and their thermowells should be checked regularly. Application parameters largely determine the frequency of inspection, but once a month is usually sufficient. It is also recommended that the extension wires used in the circuit are tested for connectivity. Damaged or burned out thermowells should be replaced to prevent damage to the process and the measuring instrument.

RTDs and thermocouples should be checked in place if possible.

**Table 1** - Recommended insertion length (U) dependent upon the diameter of the pipe (D).

(for reference only)

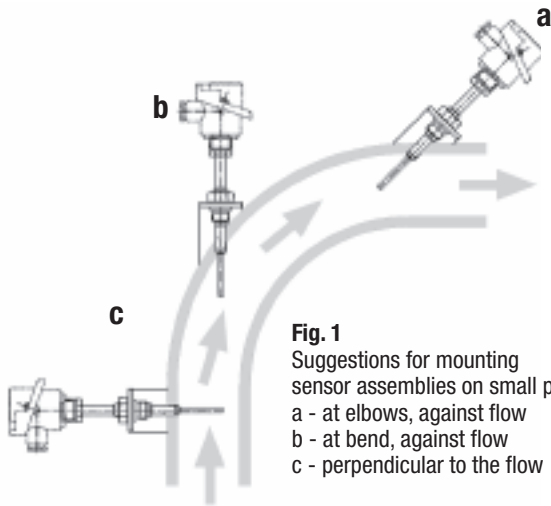

**Fig. 1**  
 Suggestions for mounting sensor assemblies on small pipes:  
 a - at elbows, against flow  
 b - at bend, against flow  
 c - perpendicular to the flow

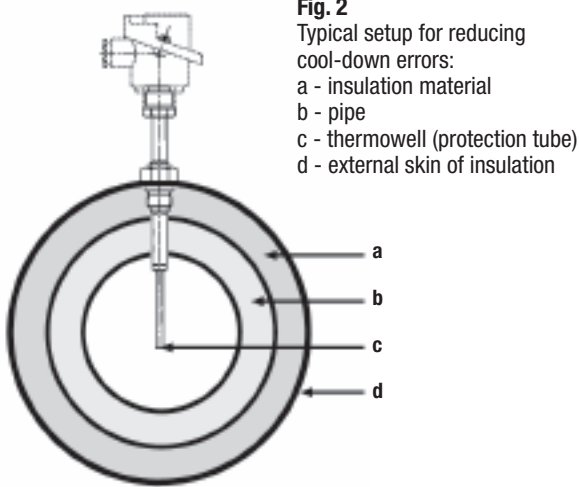

**Fig. 2**  
 Typical setup for reducing cool-down errors:  
 a - insulation material  
 b - pipe  
 c - thermowell (protection tube)  
 d - external skin of insulation

**Table 1**  
 Nominal diameter of piping (mm)

<b>D (mm)</b>	50	75	100	150	200	300	400
<b>U (mm)</b>	30	40	50	60	80	100	120