

**⚠ WARNING! READ ⚠
BEFORE INSTALLATION**

1. GENERAL:

A failure resulting in injury or damage may be caused by excessive overpressure, excessive vibration or pressure pulsation, excessive instrument temperature, corrosion of the pressure containing parts, or other misuse. Consult Ashcroft Inc., Stratford, Connecticut, USA before installing if there are any questions or concerns.

2. OVERPRESSURE:

Pressure spikes in excess of the rated overpressure capability of the transducer may cause irreversible electrical and/or mechanical damage to the pressure measuring and containing elements.

3. STATIC ELECTRICAL CHARGES:

Any electrical device may be susceptible to damage when exposed to static electrical charges. To avoid damage to the transducer the operator/installer should follow proper ESD (electrostatic discharge) protection procedures before handling the pressure transducer.

Description

The Ashcroft Model XLdp is a low pressure differential pressure transducer to be used with clean, dry air and other non-corrosive gases. Both unidirectional (e.g. 0/1.0 in. W.C.) and bidirectional (e.g. +/- 3.0 in. W.C.) pressure ranges are offered, as well as a wide selection of output signals. The storage temperature limits of the XLdp are from -40 to 180°F. The unit can operate between -20 and 160°F and is temperature compensated between 35 and 135°F.

A space on the label is provided for a grease pencil marking. This marking can identify each unit with a piece of equipment that it is monitoring. This will help to avoid tracing the pressure lines.

Mounting

The unit should be mounted with #8 or #10 screws using the two mounting slots provided. Easy access to the zero adjustment may be a consideration when mounting. The transducer can be mounted in any orientation with virtually no effect on calibration. Any minor zero pressure offsets that are encountered can be adjusted using the zero adjust potentiometer.

Piping

The two pressure connections are protected with tubing to avoid debris entering during installation. It should be left in place until system tubing is to be connected. The Ashcroft Model XLdp can withstand overpressure or vacuum of up to 15 psi without requiring recalibration.

Recommended flexible tube sizes should be as follows:

- 1/4 barb: < 3/16" ID tube
- 1/8 barb: < 1/16" ID tube

Power Requirements

Voltage Output:

The Model XLdp will operate on any supply voltage from 12-36 VDC (24 VDC typical) drawing less than 5mA.

Current Output:

The voltage required for a 4-20mA output is dependent on the loop resistance of the circuit. (See figure on electrical connections.) The Loop Resistance Chart shows the minimum supply voltage (V_{min}) required for a given Loop Resistance (R_L).

CE Options:

Available in 4-20mA output units using XCE variation. Compliant to EN61326:1997 Annex A.

Loop Resistance (Ω)

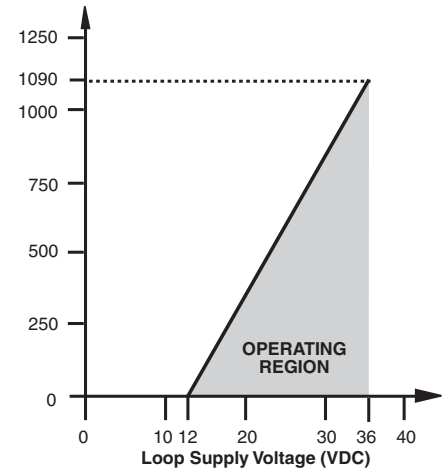

$$V_{min} = 12 + (.022A \times R_L)$$

$$R_L = R_S + R_W$$

R_L = Loop Resistance (ohms)
R_S = Sense Resistance (ohms)
R_W = Wire Resistance (ohms)

MODEL XLdp INSTRUCTION SHEET



General Dimensions (IN INCHES)

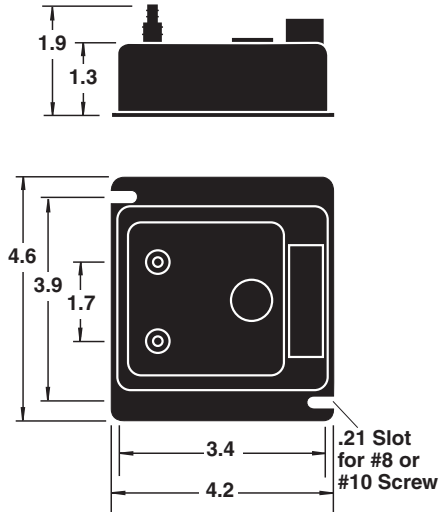

ELECTRICAL CONNECTIONS (14-22 AWG)

VOLTAGE OUTPUT

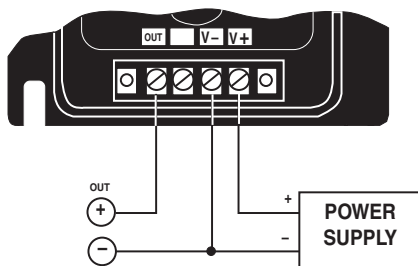

CURRENT OUTPUT

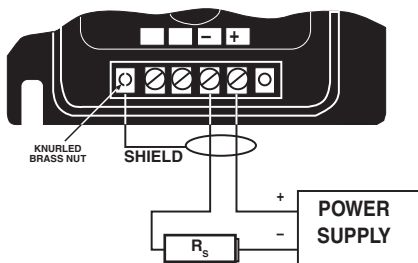

XCE Option:
Shield must be connected at instrument *only*.

Willy Instrumentos de Medição e Controle Ltda.
(An Ashcroft® Inc. Company)
Rua João Pessoa, 620 - São Caetano do Sul -
São Paulo - Brazil - 09520-000
Tel.: (55 11) 4224-7400 • Fax: (55 11) 4224-7477
vendas@ashcroft.com • www.ashcroft.com.br